

NEET PHYSICS

Topic: Centre of Mass

- The centre of mass a system of particles does not depend on :
 - masses of the particles
 - forces on the particles
 - position of the particles
 - relative distance between the particles
- In a carbon monoxide molecule, the carbon and the oxygen atoms are separated by a distance 1.12×10^{-10} m. The distance of the centre of mass from the carbon atom is :
 - 0.48×10^{-10} m
 - 0.51×10^{-10} m
 - 0.56×10^{-10} m
 - 0.64×10^{-10} m
- The centre of mass of a system of two particles divides the distance between them
 - In inverse ratio of square of masses of particles
 - In direct ratio of square of masses of particles
 - In inverse ratio of masses of particles
 - In direct ratio of masses of particles
- A ladder is leaned against a smooth wall and it is allowed to slip on a frictionless floor. Which figure represents trace of its centre of mass :-

(1)

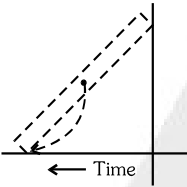

(2)

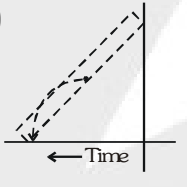

(3)

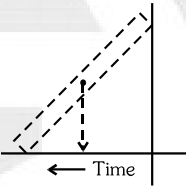

(4)

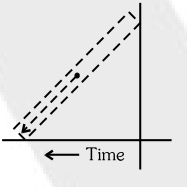
- Two spheres of masses $2M$ and M are initially at rest at a distance R apart. Due to mutual force of attraction, they approach each other. When they are at separation, the acceleration of the centre of mass of spheres would be :
 - 0 m/s^2
 - $g \text{ m/s}^2$
 - $3g \text{ m/s}^2$
 - $12 g \text{ m/s}^2$
- Choose the correct statement about the centre of mass (CM) of a system of two particles :[AMU 1995]
 - The CM lies on the line joining the two particles midway between them
 - The CM lies on the line joining them at a point whose distance from each particle is inversely proportional to the mass of that particle
 - The CM lies on the line joining them at a point whose distance from each particle is proportional to the square of the mass of that particle
 - The CM is on the line joining them at a point whose distance from each particle is proportional to the mass of that particle

8. Two particles of masses m_1 and m_2 initially at rest start moving towards each other under their mutual force of attraction. The speed of the centre of mass at any time t , when they are at a distance r apart, is
- (1) Zero (2) $(G \frac{m_1 m_2}{r^2} \cdot \frac{1}{m_1})t$ (3) $(G \frac{m_1 m_2}{r^2} \cdot \frac{1}{m_2})t$ (4) $(G \frac{m_1 m_2}{r^2} \cdot \frac{1}{m_1 + m_2})t$
9. Two bodies of masses 2 kg and 4 kg are moving with velocities 20 m/s and 10 m/s towards each other due to mutual gravitational attraction. What is the velocity of their centre of mass?
- (1) 5.3 ms^{-1} (2) 6.4 ms^{-1}
(3) zero (4) 8.1 ms^{-1}
10. Three identical metal balls, each of radius r , are placed touching each other on a horizontal surface such that an equilateral triangle is formed when the centres of the three balls are joined. The centre of mass of the system is located at :
- (1) horizontal surface
(2) centre of one of the balls
(3) line joining centres of any two balls
(4) point of intersection of their medians
11. The centre of mass of a body :
- (1) Lies always outside the body
(2) May lie within, outside on the surface of the body
(3) Lies always inside the body
(4) Lies always on the surface of the body
12. The velocities of three particles of masses 20 gram, 30 gram and 50 gram respectively. The velocity of the centre of mass of the three particles is : $10\hat{i}, 10\hat{j}$ are $10\hat{k}$ and
- (1) $2\hat{i} + 3\hat{j} + 5\hat{k}$ (2) $10(\hat{i} + \hat{j} + \hat{k})$ (3) $20\hat{i} + 30\hat{j} + 5\hat{k}$ (4) $2\hat{i} + 30\hat{j} + 50\hat{k}$
13. A sphere of diameter r is cut from a solid sphere of radius r such that the centre of mass of remaining part be at maximum distance from original centre, then this distance is : [UPSEAT 2002]
- (1) $\frac{r}{2}$ (2) $\frac{r}{3}$ (3) $\frac{r}{14}$ (4) none of these
14. If the system is released, then the acceleration of the centre of mass of the system :
- (1) $g/4$
(2) $g/2$
(3) g
(4) $2g$

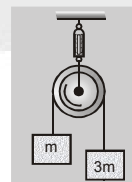

15. Initially two stable particles x and y start moving towards each other under mutual attraction. If at one time the velocities of x and y are V and $2V$ respectively, what will be the velocity of centre of mass of the system?
- (1) V (2) Zero
(3) $\frac{V}{3}$ (4) $\frac{V}{5}$

16. In the HCl molecule, the separation between the nuclei of the two atoms is about 1.27 \AA ($1 \text{ \AA} = 10^{-10} \text{ m}$). The approximate location of the centre of mass of the molecule, assuming the chlorine atom to be about 35.5 times massive as hydrogen is :

- (1) 1 \AA (2) 2.5 \AA
 (3) 1.24 \AA (4) 1.5 \AA

17. A 2 kg body and a 3 kg body are moving along the x-axis. At a particular instant the 2 kg body has a velocity of 3 ms^{-1} and the 3 kg body has the velocity of 2 ms^{-1} . The velocity of the centre of mass at that instant is :

- (1) 5 ms^{-1} (2) 1 ms^{-1}
 (3) 0 (4) $\frac{12}{5} \text{ ms}^{-1}$

18. A system consists of mass M and m ($\ll M$). The centre of mass of the system is :

- (1) at the middle
 (2) nearer to M
 (3) nearer to m
 (4) at the position of larger mass.

19. Two objects of masses 200 gram and 500 gram possess velocities $\hat{i} \text{ m/s}$ and $2\hat{j} \text{ m/s}$ respectively. The velocity of their centre of mass in m/s is :

- (1) $5\hat{i} - 25\hat{j}$ (2) $\frac{5}{7}\hat{i} - 25\hat{j}$ (3) $5\hat{i} + \frac{25}{7}\hat{j}$ (4) $25\hat{i} - \frac{5}{7}\hat{j}$

20. A cricket bat is cut at the location of its centre of mass as shown. Then

- (1) The two pieces will have the same mass
 (2) The bottom piece will have larger mass
 (3) The handle piece will have larger mass
 (4) Mass of handle piece is double the mass of bottom piece

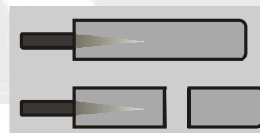

20. If linear density of a rod of length 3m varies as $\lambda = 2 + x$, then the position of the centre of gravity of the rod is :

- (1) $\frac{7}{3} \text{ m}$ (2) $\frac{12}{7} \text{ m}$ (3) $\frac{10}{7} \text{ m}$ (4) $\frac{9}{7} \text{ m}$

21. Four bodies of equal mass start moving with same speed as shown in the figure. In which of the following combination the centre of mass will remain at origin

- (1) c and d (2) a and b
 (3) a and c (4) b and d

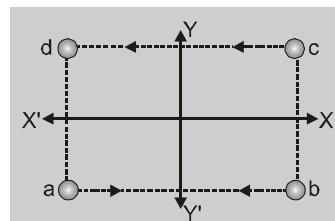

22. Three identical spheres, each of mass 1 kg are placed touching each other with their centres on a straight line. Their centre are marked P, Q and R respectively. The distance of centre of mass of the system from P is :

(1) $\frac{PQ + PR + QR}{3}$ (2) $\frac{PQ + PR}{3}$ (3) $\frac{PQ + QR}{3}$ (4) $\frac{PR + QR}{2}$

23. A uniform metal disc of radius R is taken and out of it a disc of diameter R is cut off from the end. The centre of mass of the remaining part will be:

(1) $\frac{R}{4}$ from the centre (2) $\frac{R}{3}$ from the centre (3) $\frac{R}{5}$ from the centre (4) $\frac{R}{6}$ from the centre

24. A circular plate of uniform thickness has a diameter 56 cm. A circular portion of diameter 42 cm is removed from one edge as shown in the figure. The centre of mass of the remaining portion from the centre of plate will be :

(1) 5 cm (2) 7 cm
(3) 9 cm (4) 11 cm

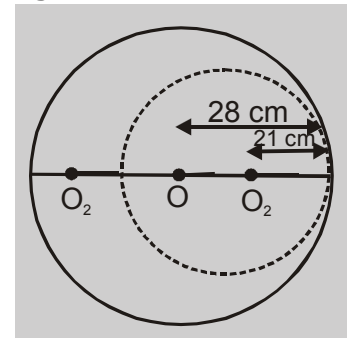

25. Three particles of masses 1 kg, 2 kg and 3 kg are subjected to forces $(3\hat{i} - 2\hat{j} + 2\hat{k})$ N, $(-\hat{i} + 2\hat{j} - \hat{k})$ and $(\hat{i} + \hat{j} + \hat{k})$ N respectively. The magnitude of the acceleration of the CM of the system is :

(1) $\frac{\sqrt{11}}{6} ms^{-2}$ (2) $\frac{\sqrt{14}}{6} ms^{-2}$ (3) $\frac{11}{6} ms^{-2}$ (4) $\frac{22}{6} ms^{-2}$

ANSWER KEY

| | | | | | | | | | | |
|------|----|----|----|----|----|----|----|----|----|----|
| Que. | 1 | 2 | 3 | 4 | 5 | 6 | 7 | 8 | 9 | 10 |
| Ans. | 2 | 4 | 3 | 2 | 1 | 2 | 1 | 3 | 4 | 2 |
| Que. | 11 | 12 | 13 | 14 | 15 | 16 | 17 | 18 | 19 | 20 |
| Ans. | 1 | 3 | 1 | 2 | 3 | 4 | 2 | 3 | 2 | 2 |
| Que. | 21 | 22 | 23 | 24 | 25 | | | | | |
| Ans. | 3 | 2 | 4 | 3 | 2 | | | | | |

